

busSTRUT

SINGLE-DECK



busSTRUT : GALVANIZED  
joiner : galvanized

DOUBLE-DECK



busSTRUT : GALVANIZED  
joiner : galvanized

JOINER

SINGLE-DECK

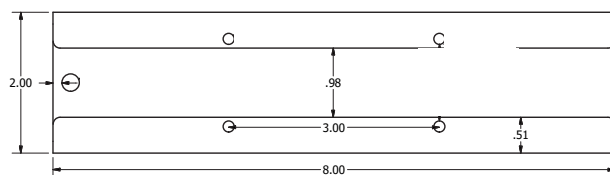
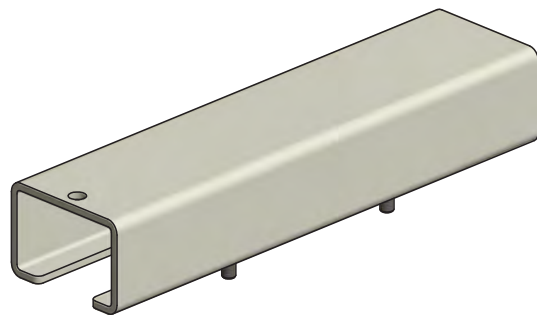
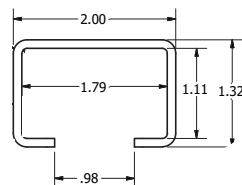
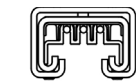

SINGLE JOINER

For use with two busSTRUT lengths. Single-Deck Joiners provide mechanical connections. Invisible screws secure the joiner to the busSTRUT lengths.

M-JB-(F)-X

Finish (F): G=Galvanized W=White B=Black

DOUBLE-DECK

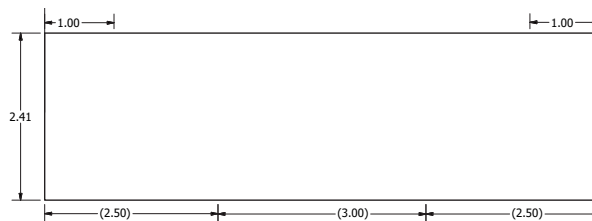
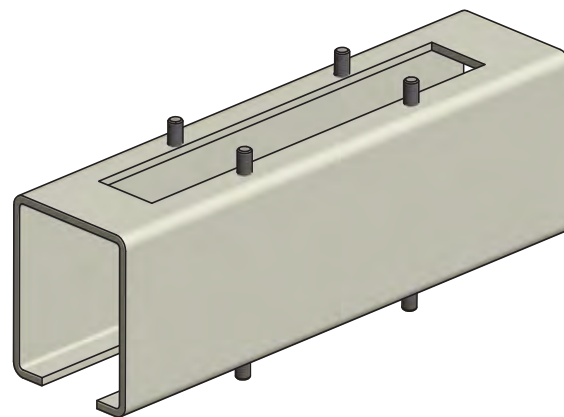
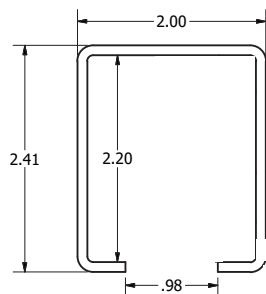
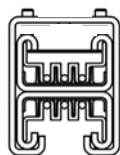

DOUBLE JOINER

For use with four busSTRUT lengths. Double-Deck Joiners provide mechanical connections. Invisible screws secure the joiner to the busSTRUT lengths.

M-JB-(F)-X

Finish (F): G=Galvanized W=White B=Black

SINGLE-DECK

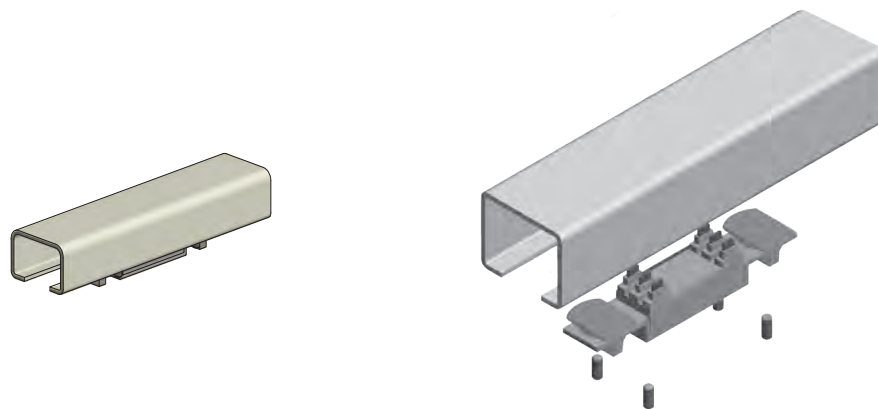

JOINER INSERT

The joiner insert is for use with any busSTRUT joiner to make the electrical connection and continue the flow of power through two abutting busSTRUT lengths.

M-JI-B-X

DOUBLE-DECK

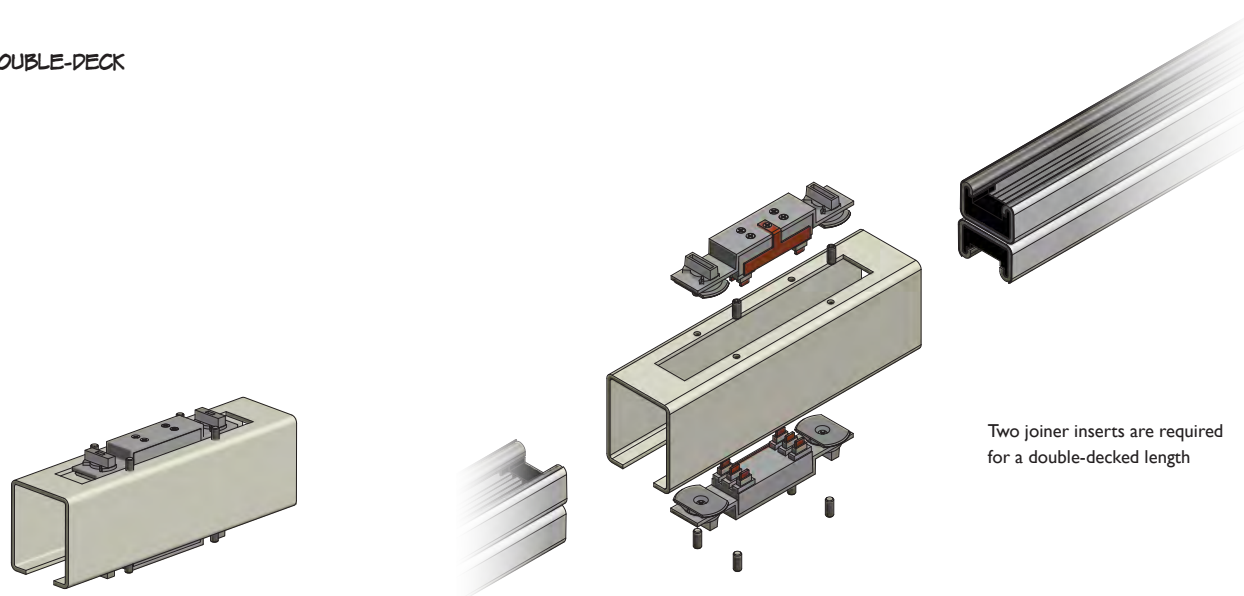

Two joiner inserts are required for a double-decked length